

SeaLife



**Mini II (SL330)
Waterproof
Shockproof
Digital Dive
& Sports Camera**

Instruction Manual
Smart Phone Format

For Español, Deutsch,
Français, Italiano and
Nederlands, please visit:

www.sealife-cameras.com/service/manuals.html

Contents

Safety Warnings	3
Check What You Got.....	4
Optional Accessories	5
Product view with call-outs: FRONT.....	6
Product view with call-outs: BACK	7
Product view: Bottom / Waterproof Door	8
Opening Waterproof Door	9
Closing Waterproof Door	10
Loading Batteries	11
Inserting /Removing Memory Card ..	12
Taking a Picture (Camera Mode).....	13
Recording a Video (Video Mode)	14
Viewing Pictures and Video Clips (Playback Mode)	15
Deleting Pictures and Video Clips (Playback Mode)	16
Easy Set-up Mode	17
Using the Zoom Function	19
Setting the Focus.....	20
Using the Flash Function	21
More About the Flash Function.....	22
Using an External Flash or Photo-Video Light.....	23
Advanced Setup Menu	24
Changing the Language	25
Changing the Date/Time	26
Using the Spy Mode	27
Changing the Auto Off setting.....	28
Changing the Beep setting	29
Changing the Display setting	30
Changing the Frame Number Reset setting	31
Changing the Light Frequency setting	32
Changing the LCD Monitor Brightness setting	33
Formatting the Memory Card or Internal Memory	34
Media and System Information	35
Using the System Reset Function	36
Using the Copy to Card Function ..	37
Transferring Pictures and Video Clips to Your Computer	38
Editing Your Pictures and Video Clips	39
Maintaining a Waterproof Seal	40
How to Clean the O-ring	41
Replacing the O-ring	42
Maintenance and Care Instructions..	43
Great Underwater pictures made easy	44-46
Troubleshooting Guide	47
Specifications	48
Parts and Service	49

Safety Warnings

Always inspect and clean the O-ring before underwater use. Follow the important waterproofing instructions on page 42 of this manual.

If water has entered the camera, immediately turn off power and discontinue use. Remove batteries and memory card, and allow the inside to dry. Contact the SeaLife service center for repairs.

Do not attempt to repair the camera. Doing so may result in electric shock, fire and will void the warranty.

Use new or freshly charged AAA-sized batteries (Alkaline, NiMH rechargeable or Lithium). Remove batteries from camera before transporting, traveling or long periods of storage.

Avoid exposing camera to high temperatures or direct sunlight for prolonged periods of time.

Safety first - Observe all applicable safety rules when using the camera for SCUBA, snorkeling or other sports.

Visit

www.sealife-cameras.com

for updates to this manual and underwater photography tips.

Check What You Got



SeaLife Camera SL330

(w/SL32070 strap)



Soft Camera Case SL33090



SD/SDHC Card Reader SL33010



Spare O-ring SL33008



Cleaning Brush / Tool SL256



Two AAA Batteries

SeaLife[®]
Limited Warranty
Garantia limitada
Garantie Limitée
Beschränkte Garantie
Garanzia limitata

Important:
Register your SeaLife product online at:
Importante:
Registre su SeaLife producto en linea en:
Important:
Enregistrez votre SeaLife produit en ligne à:
Wichtig:
Registrieren Sie das SeaLife Produkt online bei:
Important:
Registra il SeaLife prodotto da Internet all'indirizzo:

www.sealife-cameras.com/warranty

Warranty Statement



Flash Link Adapter SL33052

Optional Accessories

Available at your local authorized SeaLife dealer. Visit www.SeaLife.cameras.com to find a dealer near you.



SDHC Memory Card

(Recommend 4GB card)

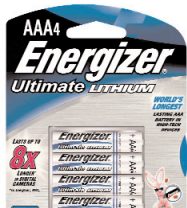

AAA batteries

(Recommend Energizer Lithium)



SeaLife Mini Wide Angle Lens SL973

For wide angle/ close-up pictures from 1ft to 3ft



SeaLife Digital Pro Flash SL961

underwater pictures



SeaLife Photo-Video Light SL980

For brighter, more colorful underwater pictures and videos



Moisture Muncher SL911

Insert two capsules inside battery compartment during storage to remove moist air trapped inside camera



Float Strap SL920

Product view with call-outs: FRONT

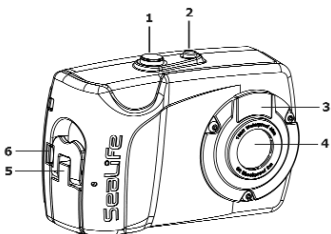

Front / Side parts

- 1 - Shutter button:**
Shoot picture,
Start/Stop Video,
Delete in Playback
- 2 - Power button:** Power
camera ON and OFF
- 3 - Flash window**
- 4 - Lens:** 9 megapixel,
F3.0, Multi-coated/
Anti-Reflective glass
optics
- 5 - Latch:** For opening
waterproof door
- 6 - Latch lock:** Prevents
accidental opening of
latch

Product view with call-outs: **BACK**

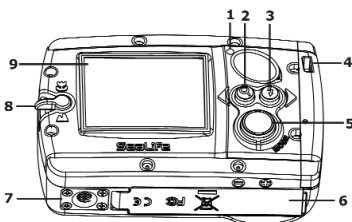

Back parts

- 1 - Status LED:** Camera ready when solid; Not ready when blinking
- 2 - Zoom/Directional button:** Adjust zoom setting or scroll left/up
- 3 - Flash/Directional button:** Adjust flash setting or scroll right/down
- 4 - Strap connection**
- 5 - Mode button:** Push to cycle through Camera, Video, Playback and Easy Setup modes. Push and hold for 3 seconds to access setup menu
- 6 - Waterproof Door:** Serial # located inside door
- 7 - Tripod mount**
(Standard 1/4-20 thread)
- 8 - Focus Lever:**
Macro (close-up) or Landscape
- 9 - LCD monitor**

Product view: **BOTTOM /** **Waterproof Door**

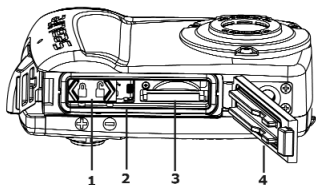

Bottom / Waterproof Door Parts

- 1 - Battery door:** 2 x
AAA Batteries
- 2 - O-ring**
- 3 - SD/SDHC memory
card slot**
- 4 - Waterproof Door:**
Serial # located inside
door

Opening Waterproof Door

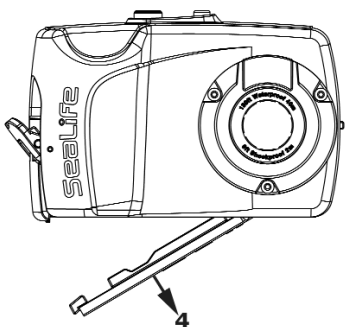
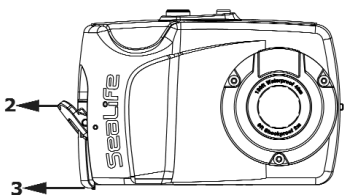
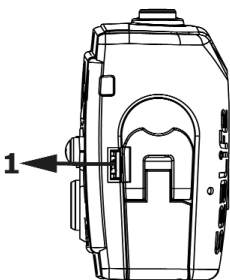

- 1) Push and hold red latch lock tab away from latch
- 2) Lift latch (Do not force beyond stopping point)
- 3) Push end of latch away from door to release door
- 4) Open waterproof door

Closing Waterproof Door

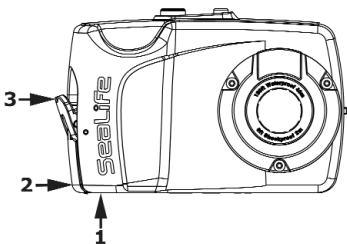

- 1) Push down on waterproof door and hold.
- 2) Push end of latch over waterproof door (*Make sure latch is unlocked as shown in the illustration*)
- 3) Close latch (*Latch lock will engage automatically*)

Important:

Before closing waterproof door, make sure O-ring and opposing contact surfaces are perfectly clean (Refer to How to Maintain a Waterproof Seal on Page 42). Make sure nothing is trapped under the door to prevent it from closing and sealing properly.

Loading Batteries

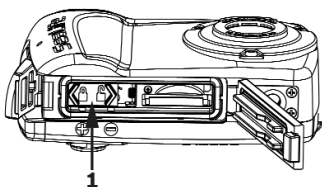

1) Slide battery door cover to unlock position.

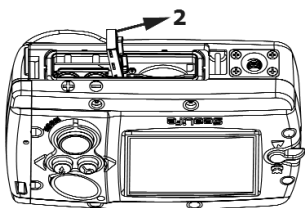

2) Spring-loaded door will open.

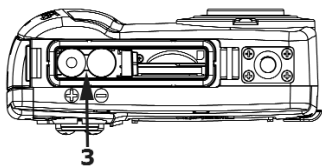

3) Insert 2 new or freshly charged AAA batteries according to the polarity markings on the camera.

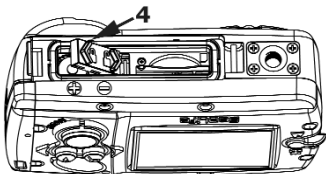

4) Push down battery door and slide to locking position.

Inserting / Removing Memory Card

(Optional)

Expand the camera's internal memory by inserting a SD/SDHC memory card (sold separately). A 4GB or 8GB SDHC card is recommended.

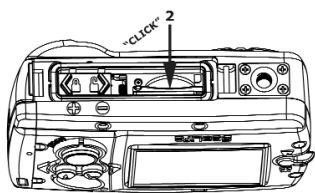
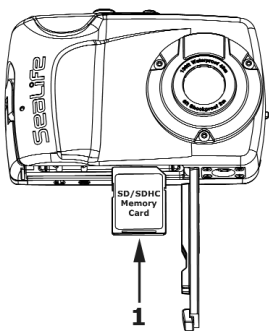





- 1) Insert memory card in correct orientation as shown.
- 2) Push card into slot all the way until it clicks in place.
- 3) To remove card, make sure camera power is turned off. Push lightly on the edge of the card and it will eject. Use end of Cleaning Brush / Tool provided for easier removal of card.

Notes: You should format the memory card when it's first installed or when the card is used in another camera. Refer to page 35 for instructions on formatting the memory card. Each 1GB of memory card storage size is equal to about 900 pictures or 30 minutes of video. For example, 4GB card will store about 3600 pictures or 2 hours of video.

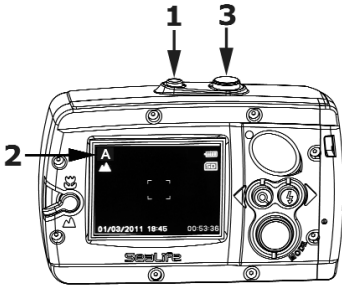
Taking a Picture

(Camera Mode)



- 1) Power ON camera.
- 2) One of the Camera mode icons
[   ]
is displayed on the upper left corner of the LCD monitor.
- 3) Compose the image on the LCD monitor, hold the camera steady and push the Shutter button to take a picture.

Notes:

- Refer to page 18 for more information about the four different camera modes.
- The camera will automatically go into power save mode when no buttons are pushed for a period of one minute. The LCD will turn off but the Status LED light remains on. Push any button to “wake-up” the camera
- The power is turned OFF automatically when the camera has not been operated for a fixed period of time. Turn the power ON again to resume operation. Refer to Setting Auto-Off on page 29.
- The LCD monitor will display the last picture for 1-second immediately after taking the picture.
- Changing the Focus, Flash and Zoom setting is described later in the manual.

Recording a Video

(Video Mode)

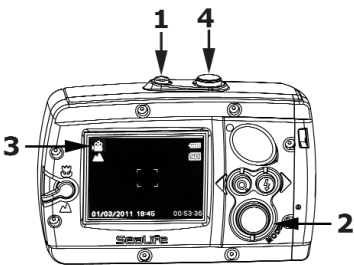

- 1) Power ON camera.
- 2) Push the Mode button once to select Video mode.
- 3) The Video mode icon [] is displayed on the upper left corner of the LCD monitor.
- 4) Compose the opening scene on the LCD monitor and push the Shutter button to start recording video.
- 5) The "REC" icon and elapse time is displayed on the bottom of the LCD monitor indicating the camera is now recording video.
- 6) Hold camera steady and pan slowly when recording video.
- 7) Push the Shutter button again to stop recording video.

Notes:

- There must be sufficient lighting for good quality video. Use the SeaLife Photo-Video Light SL980 (Optional accessory) for recording video in low light conditions.
- Changing the Focus and Zoom setting is described on pages 19-20.
- The Zoom cannot be adjusted during video recording.
- The Flash cannot be used when recording video.

Viewing Pictures and Video Clips

(Playback Mode)

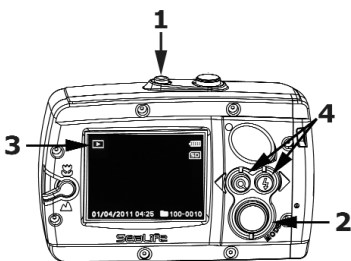

- 1) Power ON camera.
- 2) Push the Mode button twice to set camera to Playback mode.
- 3) The Playback icon [] is displayed on the upper left corner of the LCD monitor and the last recorded picture or video clip will be displayed on the LCD monitor.
- 4) Push the left or right Directional button to scroll through the pictures and video clips stored in memory.

Note:

- Video clips will start playing automatically. Push and hold the left Directional button to reverse the video clip.

Deleting Pictures and Video Clips

(Playback Mode)

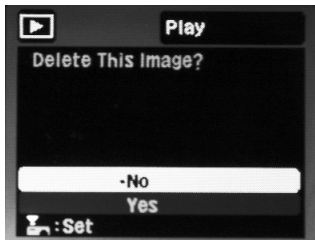

- 1) To delete a picture or video clip, use the left or right Directional button to scroll through the pictures until the picture or video clip you want to delete is displayed.
- 2) Push the shutter button.
- 3) The LCD monitor will display "Delete This Image?" - "Yes" or "No".
 - a. Push the left or right Directional button to select "Yes" and push the Shutter button to delete the picture or video.
 - b. Push the left or right Directional button to select "No" and push the Shutter button to exit. Picture will NOT be deleted.

Note:

- You can also delete all images and videos stored in memory by formatting the memory card. Refer to page 35 for information on formatting the memory card.

Easy Set-up Mode

The Easy Set-up mode is a fast and easy way to set the camera for underwater or land use.

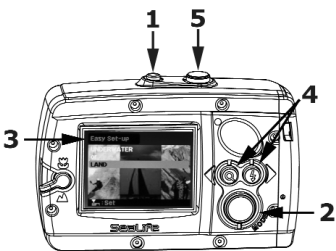

- 1) Power ON camera.
- 2) Push the Mode button three times to set camera to Easy Set-up mode.
- 3) "Easy Set-up" is displayed on the upper left corner of the LCD monitor.
- 4) Follow the on-screen guide using the left or right Directional button to make your selections.
- 5) Push the Shutter button to confirm selection.
- 6) Once you have completed the Easy Set-up, the camera will automatically exit the Easy Set-up mode and return to the Camera mode.

Easy Set-up Mode

(Continued)

When finishing the Easy Setup, the camera will be set to one of the following four shooting modes:



Land Auto – Ideal for taking pictures or video clips on Land.



Underwater ➔

Camera+Flash – Ideal for taking underwater pictures or videos when using the optional external flash and/or photo-video light accessory.



Underwater ➔ Camera Only ➔ Snorkeling -

Ideal for taking underwater pictures or videos without external flash or light accessory at depths less than 20ft/6m



Underwater ➔ Camera Only ➔ Diving -

Ideal for taking underwater pictures or videos without external flash or light accessory at depths greater than 20ft/6m

Using the Zoom Function

The camera is equipped with 3X digital zoom, which is useful to magnify far away subjects. Use a tripod or place the camera on a stable surface when using 3X zoom to avoid blurry pictures.

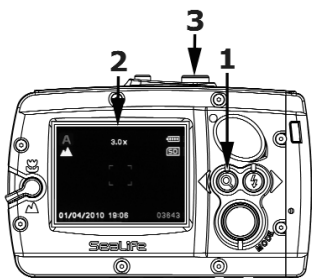

- 1) To activate the zoom push and release the Zoom button.
- 2) Each push and release will increase the zoom by one step up to 3X. The magnification is displayed on the LCD monitor.
- 3) Compose your scene and push the shutter button to take a picture or start recording video

Note:

- The Zoom cannot be adjusted during video recording.

Setting the Focus

The camera is equipped with a Focus Lever for taking pictures or videos at close-up or far away subjects.

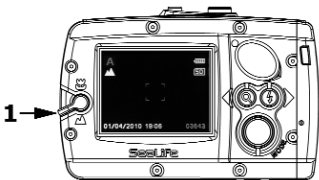

- 1) Turn Focus Lever to Landscape [] for shooting distances of 4ft to infinity (1.3m to infinity)

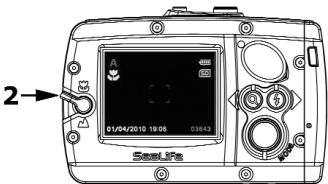

- 2) Turn Focus Lever to Macro [] for close-up shooting distances between 2ft to 4ft (0.65m to 1.3m)

Notes:

- The Focus setting will be displayed on the LCD monitor

Using the Flash Function

The camera's built-in flash is useful for taking pictures in low light conditions, like indoors or at night. There are 4 possible flash modes: Auto, Flash ON, Flash OFF, Red Eye Reduction.

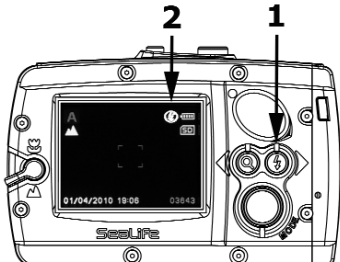

1) Push the Flash button to change flash to desired setting. The flash setting options are described below.

2) The Flash setting will be displayed on the LCD Monitor.

Flash mode

Description

Auto [no icon]

The flash fires automatically according to the lighting conditions.

Flash ON



The flash will always fire regardless of the lighting conditions. This option is useful when the subject is set against a bright background or to reduce dark shadows.

Flash OFF



The flash is turned off and will not fire regardless of the lighting conditions. Turn the flash off when taking pictures at shooting distances beyond the effective range of the flash (approximately 10ft/3m on land or 3ft/1m underwater).

Red-eye Reduction



Use this mode to reduce the red-eye phenomenon when taking pictures of humans or animals in low-light conditions.

More About the Flash Function

- The Flash cannot be used when recording video.
- It is recommended to keep the flash turned off when taking underwater pictures, unless you are shooting in perfectly clear water at close-up shooting distance inside of 3 ft/1m or using the optional external flash accessory. Keeping the flash turned OFF or using the optional flash accessory reduces backscatter (figure 1). Backscatter refers to the small dots that appear in underwater pictures, which occurs because the tiny particles suspended on the water are illuminated by the camera's flash. Keeping the flash ON increases backscatter (figure 2).

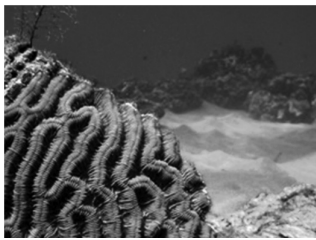

Figure 1

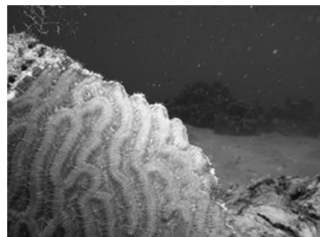

Figure 2

Using an External Flash or Photo-Video Light (Optional Accessories)



SL961 Digital Pro Flash



SL980 Photo-Video Light

- Use the SeaLife SL961 Digital Pro Flash and/or SL980 Photo-Video Light (optional accessories) for brighter, more colorful underwater pictures or videos with reduced backscatter. Visit www.sealife-cameras.com for more information.
- When using the optional SL961 external flash or SL980 photo-video light accessories, follow the Easy Setup mode to set the camera to UNDERWATER ➔ CAMERA + FLASH. This optimizes the camera's exposure program to compensate for the more powerful light emitted from the external flash or light. The camera's flash is locked to FLASH ON. Pushing the Flash button will adjust the exposure setting of the camera. The default setting is Normal.

Advanced Setup Menu

The camera has a hidden advanced Setup menu used for changing the Date/Time, Language and other one-time or advanced settings.



- 1) Power ON camera.
- 2) Push and hold the mode button for 3 seconds until the Setup menu is displayed on the LCD monitor.
- 3) Use the right or left Directional buttons to scroll up and down the setup menu.
- 4) Use the Mode button to confirm the desired setting.
- 5) To exit the menu, push and hold the Menu button for 3 seconds or select "Exit" from the menu and push the Mode button.

Changing the Language

(Advanced Setup Menu)

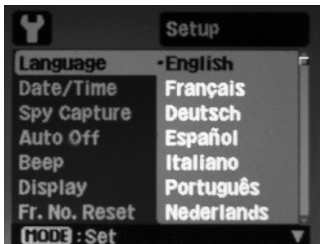

- 1) Open the advanced Setup menu as described on page 24.
- 2) Select “Language” from the setup menu using the right or left Directional buttons and push the Mode button to enter the Language setting screen.
- 3) Select the desired language using the right or left Directional buttons and push the Mode button to confirm.

Changing the Date/Time (Advanced Setup Menu)

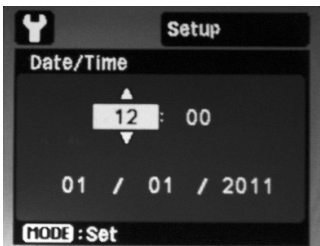

- 1) Open the advanced Setup menu as described on page 24.
- 2) Select "Date/Time" using the right or left Directional buttons and push the Mode button to enter the Date/Time setting screen.
- 3) The time is displayed in 24-hour HH:MM format and the date is displayed in MM/DD/YYYY format.
- 4) Adjust the number values using the left [or right] to increase [or decrease] the value and push the Mode button to confirm each setting.

Note:

- The Date/Time setting will not be saved if the battery is removed for more than 3 minutes.

Using the Spy Mode

(Advanced Setup Menu)

In Spy Mode, the camera will automatically capture continuous pictures of a scene at specified time intervals. The Spy mode is useful for taking multiple pictures of hard-to-photograph wildlife, sealife or scenery without being discovered, and later selecting the best image.



- 1) Open the advanced Setup menu as described on page 24.
- 2) Select "Spy Capture" using the right or left Directional buttons and push the Mode button to enter the Spy Capture setting screen.
- 3) Two options are displayed: "Single" for taking one picture at a time and "Spy" for taking continuous pictures.
- 4) Select "Spy" using the right or left Directional buttons and push the Mode button to confirm.
- 5) The "Set Time Interval of Capture" screen is displayed on the LCD monitor.
- 6) Use the right or left Directional buttons to select the desired time interval: 5 sec, 10 sec, 30 sec, 1 min, 5 min or 30 min.
- 7) Push the Mode button to confirm the time interval.
- 8) The advanced setup menu will automatically close and you will see the spy mode icon [] displayed on the LCD monitor.
- 9) Aim the camera at the desired scene. A compact tripod is helpful to keep the camera aimed at the subject.
- 10) Push the shutter button. The camera will count down from 2 seconds and take the first picture.
- 11) The LCD monitor will turn off to conserve battery power. The camera will continue taking pictures at the pre-set time interval until the shutter button or power button is pushed, the memory is full, or the battery is empty.

Changing the Auto Off setting

(Advanced Setup Menu)

The Auto Off function will automatically turn OFF the camera power when the camera has not been operated for a fixed period of time. You can set the desired Auto Off time period (1 min, 2 min or 3 min) or disable the Auto Off feature (Off).



- 1) Open the advanced Setup menu as described on page 24.
- 2) Select "Auto Off" using the right or left Directional buttons and push the Mode button to enter the Auto Off setting screen.
- 3) Select the desired time period using the right or left Directional buttons and push the Mode button to confirm.

Changing the Beep setting

(Advanced Setup Menu)

The camera will make a beeping sound when a button is pushed buttons. You can set the Beep to On or Off.



- 1) Open the advanced Setup menu as described on page 24.
- 2) Select “Beep” using the right or left Directional buttons and push the Mode button to enter the Beep setting screen.
- 3) Select On or Off using the right or left Directional buttons and push the Mode button to confirm.

Changing the Display setting

(Advanced Setup Menu)

The LCD monitor will display the camera setting icons, date/time and other status information. You can set the camera to display all icons (ALL) or no icons (OFF).



- 1) Open the advanced Setup menu as described on page 24.
- 2) Select "Display" using the right or left Directional buttons and push the Mode button to enter the Display setting screen.
- 3) Select ALL (display icons) or OFF (do not display icons) using the right or left Directional buttons and push the Mode button to confirm.

Changing the Frame Number Reset setting (Advanced Setup Menu)

This feature will create a new folder on the memory card.

The captured pictures and video clips are saved in the new folder starting at frame number 0001.

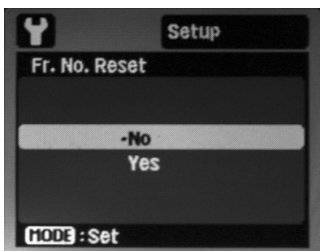

- 1) Open the advanced Setup menu as described on page 24.
- 2) Select "Fr. No. Reset" using the right or left Directional buttons and push the Mode button to enter the Fr. No. Reset setting screen.
- 3) Select No (exit) or Yes (create new folder) using the right or left Directional buttons and push the Mode button to confirm.

Changing the Light Frequency setting (Advanced Setup Menu)

Change the camera's light frequency setting to match the electrical system used in your country. This will prevent the LCD monitor from flickering under fluorescent lighting conditions. Select 60 Hz (default) for North and Central America and 50 Hz for Europe and most other parts of the world.



- 1) Open the advanced Setup menu as described on page 24.
- 2) Select "Light Freq." using the right or left Directional buttons and push the Mode button to enter the Light Freq. setting screen.
- 3) Select 60Hz or 50Hz using the right or left Directional buttons and push the Mode button to confirm.

Changing the LCD Monitor Brightness setting

(Advanced Setup Menu)

Use this setting to increase the brightness of the LCD monitor. You can select between Standard (default) or Bright. The Bright setting makes it easier to see the LCD monitor in bright light conditions, but will also use up the battery power more quickly.

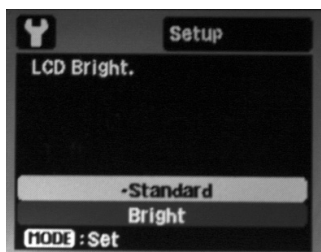

- 1) Open the advanced Setup menu as described on page 24.
- 2) Select "LCD Bright." using the right or left Directional buttons and push the Mode button to enter the LCD Bright. setting screen.
- 3) Select Standard or Bright using the right or left Directional buttons and push the Mode button to confirm.

Formatting the Memory Card or Internal Memory

(Advanced Setup Menu)

Use this function to reset or clear the memory card or internal memory. Caution: All images and data saved on the memory card or internal memory will be deleted. It is recommended to format the memory card before its initial use or after the card has been used in another camera or device. It is also a convenient way to delete all pictures and video clips after being saved on your computer.

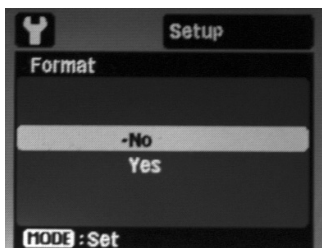

- 1) Open the advanced Setup menu as described on page 24.
- 2) Select "Format" using the right or left Directional buttons and push the Mode button to enter the Format setting screen.
- 3) Select Yes (format) or No (exit) using the right or left Directional buttons and push the Mode button to confirm.

Media and System Information

(Advanced Setup Menu)

Media Information (Media Info.) will display the memory card size and amount of memory storage remaining in megabytes (MB).

System Information (Sys. Info.) will display the firmware version installed on the camera. New firmware may be released to repair bugs in the operating system or improve the camera performance. Any new firmware versions would be posted on the www.sealife-cameras.com and available for free download.

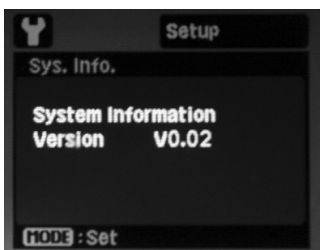

- 1) Open the advanced Setup menu as described on page 24.
- 2) Select "Media Info" or "Sys. Info." using the right or left Directional buttons and push the Mode button to enter the information screen.
- 3) Push the Mode button to exit the information screens.

Using the System Reset Function

(Advanced Setup Menu)

Use this function to restore the camera's original default settings. The time setting will not be reset.

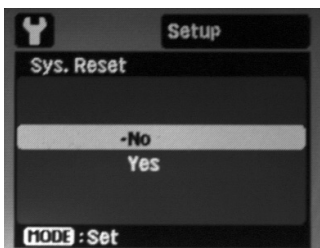

- 1) Open the advanced Setup menu as described on page 24.
- 2) Select "Sys. Reset" using the right or left Directional buttons and push the Mode button to enter the Sys. Reset setting screen.
- 3) Select Yes (reset) or No (exit) using the right or left Directional buttons and push the Mode button to confirm.

Using the Copy to Card Function

(Advanced Setup Menu)

Use this function to copy the pictures and video clips saved in the camera's internal memory to the SD/SDHC memory card. You can only use this when the memory card is installed and you have pictures or video clips saved in the camera's internal memory.

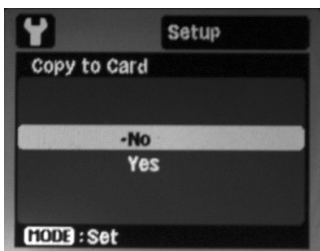

- 1) Open the advanced Setup menu as described on page 24.
- 2) Select "Copy to Card" using the right or left Directional buttons and push the Mode button to enter the Copy-to-Card setting screen.
- 3) Select Yes (copy to card) or No (exit) using the right or left Directional buttons and push the Mode button to confirm.

Transferring Pictures and Video Clips to Your Computer

Use the SD/SDHC Card Reader provided to transfer pictures from the memory card to your computer.

- Remove the memory card from the camera. Refer to page 12 for information on how to install/remove the memory card.



- Insert the Memory Card into Card Reader and Card reader into the computer USB port as illustrated.
- Your PC or MAC computer will automatically detect the card reader.
- For Windows, double click “Computer” located on the desktop, and look for “Removable Disk”.
- Double-click “Removable Disk” and you will see the DCIM folder, which contains the pictures and video clips saved on the inserted memory card.
- Copy or Cut the pictures and video clips contained in the folder and Paste to the desired folder location on your computer.

Notes:

- For Mac, double-click the “Untitled” or “Volume 1” folder that appears on your desktop. iPhoto should launch automatically.

Editing Your Pictures and Video Clips

Almost every computer includes picture and video editing software, like Windows Photo Gallery, Movie Maker or Mac iPhoto. Editing software allows you to open, view, organize and make edits adjustments to your pictures and video clips. If your computer does not include editing software, you may want to purchase one. Here are some links to popular photo editing software:

Google Picasa:

www.picasa.google.com

Adobe Photoshop Elements:

www.adobe.com

Arcsoft Photo Studio:

www.arcsoft.com

Ulead PaintShop:

www.ulead.com

Maintaining a Waterproof Seal - IMPORTANT

The camera uses one O-ring to maintain a waterproof seal. The O-ring is located under the waterproof door. Follow these important O-ring care instructions or the camera may flood

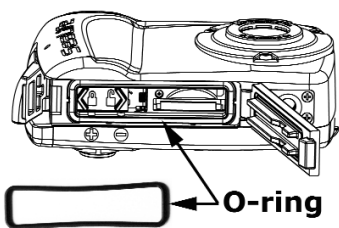

- Do not lubricate O-ring.
- Inspect O-ring and O-ring contact surfaces for damage (cuts, scratches, tears, cracks, dents and any other imperfections.) before each use. Replace O-ring if damaged or have camera serviced if the O-ring contact surfaces become damaged.
- Clean O-ring and O-ring contact surfaces, removing all sand, hair and other debris before every use. Use the cleaning brush provided or wipe the O-ring and O-ring contact surfaces with clean moistened cloth.
- Make sure O-ring is completely seated into O-ring groove before sealing the waterproof door.
- Make sure there are no obstructions preventing the waterproof door from closing or sealing properly.
- Do not exceed the depth rating of 40m (130ft) or the camera may leak or become damaged.
- Replace O-ring every year to ensure proper seal. Refer to page 44 for information on replacing the O-ring.

How to Clean the O-ring



- 1) Remove the O-ring using the end of the cleaning brush provided.

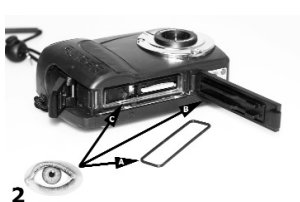

- 2) Inspect O-ring(A), contact surface(B) and O-ring groove(C) for cuts, scratches, tears, cracks, dents or other damages before each use. Replace O-ring if damaged or have camera serviced if the O-ring contact surfaces become damaged.

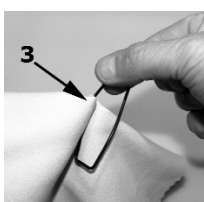

- 3) Use a damp, lint-free cloth to clean O-ring and O-ring contact surfaces, removing all sand, hair and other debris.



- 4) Use the cleaning brush provided to remove any sand or debris from the O-ring groove, waterproof door and sealing area.

- 5) Install O-ring (see next page).

Replacing the O-ring

Replace the O-ring if damaged or at least once per year. Only use approved SeaLife O-ring - Item # SL33008. One spare O-ring is included. Additional O-rings may be purchased at your local authorized SeaLife dealer, or online at www.sealifepartsdirect.com (USA Only).

To Remove O-ring:

- 1) Open the waterproof door. Refer to page 9 for instructions on opening and closing the waterproof door.
- 2) Use the end of the Cleaning Brush / Tool or the side of a credit card to lift the O-ring out of its groove.

To Install O-ring:

- 1) Make sure O-ring, O-ring groove and O-ring contact surfaces are perfectly clean and undamaged for installing the O-ring.
- 2) Lay O-ring flat along the O-ring groove. Be careful not to roll or twist O-ring.
- 3) Gently push O-ring down into the groove until the O-ring is completely seated into the groove. Do not lube O-ring.

Maintenance and Care Instructions - **IMPORTANT**

Follow these important camera care instructions or the camera may become damaged or flood.

- Soak and rinse sealed camera under running water or in fresh water tub for about 2 minutes after underwater use or when dirty. Press each button several times to clean out any saltwater, sand or dirt that may be trapped under the buttons. Towel dry and place camera button-side down to allow excess water to drain from the buttons.
- Do not let any water or dirt enter the camera's battery compartment or memory card slot when waterproof door is opened. This may result in damage to the camera electronics.
- Make sure that you and the camera are completely dry before opening the waterproof door or changing the batteries or the memory card.
- Avoid opening waterproof door in wet, sandy or humid environments. It is recommended to load batteries and prepare the camera in dry cool air, such as inside an air conditioned room. This will prevent water or humidity from being trapped inside the camera, which may cause fogging to occur.
- Avoid exposing camera to direct sunlight or extreme high temperatures, such as the trunk of your car, for prolonged periods of time.
- The camera is negatively buoyant and will sink in water. Recommend purchasing optional float strap (SL920).
- Attach the strap to your wrist or buoyancy control device (BCD) when using the camera in or near water.
- Make sure camera is cleaned and completely dry before storing.
- Store camera at room temperature in a clean and dry place. Remove batteries. Leave waterproof door unlatched when storing camera for 3 months or longer.

Great Underwater pictures made easy

Most people are familiar with taking pictures and videos on land, but there are plenty of challenges that photographers face in the underwater world. The following information summarizes the basic principles of underwater photography.



Crystal clear water is essential for good underwater pictures. Low visibility, caused by fine particles suspended in the water, will diminish the picture and video quality.



Limit your shooting distance to 1/10 of the water visibility. For example, if the visibility is 30ft/10m, limit your shooting distance to 3ft/1M. Closer shooting distances result in better pictures. Consider buying the Mini Wide Angle Lens accessory (SL973), which allows you to keep a closer shooting distance and fit everything into the picture.



Control your buoyancy and set yourself up in the ideal position before taking a picture or shooting video. This allows you to hold the camera steady and control your shooting distance. Good buoyancy control will help you avoid stirring up the sandy bottom which will cloud-up the water and cause backscatter. Controlling your buoyancy is very important for your diving safety so don't start shooting until your buoyancy is under control.

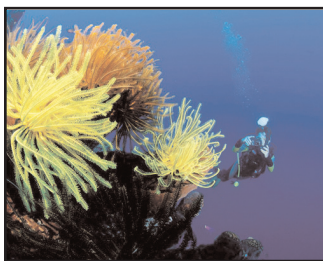

Compose a good picture. Avoid shooting down on the subject from above. Shooting down usually results in a poor contrast because the subject blends into the background. Try and shoot upwards from below the subject so you get a blue water background and better contrast. Get the entire subject into your picture frame. Don't cutoff the hands, fins or head of your subject. You can always crop you image later on your computer if you want.

Video tips

Hold the camera as steady as possible and move (pan) very slowly. A jumpy, fast-moving video is hard for anyone to watch.

Avoid shooting video clips more than 1 minute. It is difficult to edit a lengthy video clips because the large file size. You can always patch together short video scene into a longer movie using video editing software, like Microsoft Movie Maker.

Practice makes perfect

There is no better way to learn than from your mistakes. Become familiar with your camera controls so you can make quick adjustments depending on the conditions. Take the time to practice and experiment with different settings. Review your pictures and learn from your mistakes

Always observe dive safety rules and Never Touch Marine Life

Do not let photography distract you from diving safely. Observe marine life - Never touch marine life. Be aware of your surroundings to avoid contacting anything. Keep your dive gear close to your body.

Troubleshooting Guide

Camera does not power ON

Check the battery polarity and if batteries are new or fully charged.

Blue or dark underwater pictures/videos

Use Easy Set-up mode to set camera for underwater.

Keep flash turned off unless shooting close-up distances in clear water, or unless using the optional external flash accessory. Turning the flash ON while underwater disables the underwater color correction feature.

Consider purchasing the SeaLife Digital Pro Flash (SL961) for brighter, more colorful pictures.

Pictures or Video clips are not sharp

The focus switch is not set correctly. Refer to page 20 for more information on setting the focus and correct shooting distances.

Light conditions are too dark resulting in grainy pictures or motion blur. Hold camera steady or use optional external flash or light accessory.

The lens is dirty - Clean the lens using a damp cotton cloth and dry.

For more troubleshooting information and technical updates, please refer to the SeaLife website at www.sealife-cameras.com or contact your local SeaLife dealer or service center for help.

Specifications

Image Sensor:

9.0 mega pixel CMOS image sensor

Color: 24-bit color (RGB)

Image Resolution: 9mp (3472x2604)

Picture file format: JPEG

Movie Resolution: VGA (640x480)
at 30 frames per second

Video file format: MJPEG (.AVI)

Lens: F3.0 / 7.9mm
(film equivalent = 45mm)

Focus type: Instant fixed-focus
lens (2ft /0.65m to infinity)

Zoom: 3x Digital zoom

Shutter speed: Mechanical shutter
(1 to 1/2000 second)

Flash: Auto, Fill, Off, Red-Eye
Reduction

Picture modes: Auto, Snorkel
(underwater), Sea, Ext Flash

Shooting modes: Single, SPY Mode

LCD: 2.4" color TFT LCD

Memory: Internal: 28 MB
(10 hi-res pictures) External: SD
and SDHC card (Recommend
4GB or 8GB SDHC card)

EXIF Format: EXIF 2.2

Operating Environment:
PC: Windows XP/Vista/7 or
MAC: OS 9.0 and up

On-Screen language: English,
German, French, Spanish,
Italian, Russian, Dutch, Turkish,
Portuguese (Brazil), Chinese
(T-C and S-C)

Instruction manual: English
(printed), German, French,
Spanish, Italian, Dutch

Power: AAA Battery x 2

Battery life: 100 pictures
w/Alkaline (500+ pics w/Energizer
Ultimate)

Certifications: CE, ROHS, FCC

Weight: 10 oz. (286g) w/strap

Dimensions: 4.5" x 1.8" x 3.0"
(11.4cm x 4.6cm x 7.6cm)

Depth: Individually depth
tested to 130ft (40 m)

Buoyancy: Slightly negative

Operating temp: 33 degrees F
to 110 degrees F

Storage temp: -20 degrees F
to +140 degrees F

Tripod mount: Standard 1/4 -20
tripod threads

Warranty: 1 year limited warranty.

Parts and Service

SeaLife guarantees the original purchaser of this product, for a period of one (1) year from the date of purchase, that the product is free from defects in workmanship and materials. For detailed warranty information, please refer to the warranty statement included with the product. In the event the original purchaser believes there is a defect in a product, it is recommended that the purchaser first visit www.sealife-cameras.com for product updates and technical advice. The SeaLife website also includes detailed information on how to get repair service.



Pioneer Research

www.sealife-cameras.com